



OASIS CLEARWATER MBR

(MEMBRANE BIOREACTOR WASTEWATER TREATMENT SYSTEMS)

OWNER OPERATION & INSTALLATION MANUAL

PLEASE READ

We urge you to fully read this Manual. The contents are important to your safety and the operation of the Oasis MBR Wastewater Treatment system.

Keep this Manual with other important household manuals for future reference.

If you have questions regarding the safety and operation of your Oasis MBR Sewage Treatment System, contact your local Authorised Service Technician.

- Do not attempt to service components of the system yourself; call your Accredited Service Technician.
- Only Authorised Service Personnel are to remove covers on the Treatment System

TABLE OF CONTENTS

SECTION 1.	INTRODUCTION
SECTION 2.	HOW THE OASIS MBR WORKS
SECTION 3.	INTRODUCING PRODUCTS INTO THE SYSTEM
SECTION 4.	SYSTEM MAINTENANCE AND MONITORING
SECTION 5.	LIMITED WARRANTY
SECTION 6.	MANAGEMENT PLAN
SECTION 7.	TROUBLE SHOOTING
SECTION 8.	COMMISSIONING AND SERVICING PROCEDURES
SECTION 9.	EXCAVATION DETAILS
SECTION 10.	ELECTRICAL REQUIREMENTS

SECTION 1

INTRODUCTION

Thank you for choosing the Oasis MBR Wastewater Treatment System for your property.

The Oasis MBR is one of the finest membrane bioreactor filtration Wastewater Treatment Systems available today.

Our System converts the sewage from your residence or business into a clear odourless liquid. The high degree of treatment is accomplished at a remarkably low operating cost per month.

SECTION 2

HOW THE OASIS MBR WORKS

ENGINEERED TO PERFECTION!

Why this Technology is so effective

- The system comprises a pre-treatment chamber feeding to the MBR chamber, further biological and mechanical filtration occurs by the use of the revolutionary ZABEL A300 high performance filter, prior to MBR filtration chamber. Oasis Clearwater has perfected the MBR filtering system the most environmentally friendly, technically superior sewage system on the market today.
- The Kubota system utilizes flat sheet membrane panels, several of which are mounted in a membrane cartridge, the cartridge is submerged in the MBR chamber for filtering of the liquid as liquid passes through the pores (effective pore size 0.01 micron) this effectively removes bacteria suspended solids and most viruses. The resulting irrigation water easily exceeds both the New Zealand and Australian stringent standards for the disposal of wastewater.
- Membrane filtering produces high quality water-ideal for re-use.
- The system is controlled by a high quality PLC (programmable logic controller) with audio-visual alarm detection for system operation and malfunction.

SECTION 3

INTRODUCING PRODUCTS INTO THE SYSTEM

Introducing harmful products into the system may reduce the efficiency of the system or stop the treatment process by destroying the biomass. These products that reduce the efficiency or stop the treatment process can be grouped into two groups, prohibited substances and limited-use substances. While the wastewater treatment system will process most waste produced by the average household, the following information will maximise the system's efficiency and reduce the time period between primary chamber pump-outs.

NOTICE: Introducing harmful or damaging chemicals into your Oasis MBR System may void the Warranty.

A. Prohibited Substances:

Prohibited substances are those substances which when present in even small amounts will prevent the system from providing wastewater treatment. Substances that will not dissolve may clog and possibly damage the aeration unit. **DO NOT** introduce the following prohibited substances into your Oasis MBR System:

- Plastic or rubber products, petroleum products, such as motor oil, paint, paint thinner, petrol and solvents
- Non-biodegradable products, such as sanitary napkins, condoms and disposable napkins
- Toxic substances such as pesticides, strong disinfectants and strong caustic drain cleaners
- Large amounts of paper products, such as paper towels and synthetic fibre-reinforced products advertised as having "wet strength"
- Animal fats, such as bacon grease or lard (normal cleaning of pots and pans is acceptable).

Chemicals

The following chemicals are prohibited substances and **should not be** poured into the Treatment System:

Herbicides Pesticides Paint Thinner Motor Oil

Have you read the "Essential Guidelines"?

(enclosed with your system information)

B. Limited-Use Substances:

Limited-Use substances in large concentration will reduce or stop the treatment process. The same substances in smaller concentrations will have no harmful effect on the treatment process. You may use the following substances without harming your Oasis MBR Treatment System if you use the substance according to the manufacturer's directions, use the substances SPARINGLY, and do not introduce concentrated doses into the system.

Bio-degradable laundry powders

Laundry Bleach

Detergents with Bleach

Household cleaners containing sodium bactericides such as:

- Pine oil (disinfectant used in general purpose liquid cleaners)
- N-alkyl dichlorobenzyl ammonium chloride (disinfectant used in detergents and spray cleaners)
- Sodium hydroxide (lye-chemical used in drain openers and cleaners)
- Sodium dichlor-s-triazinetrione (powdered bleach used in scouring powders and automatic dishwasher detergents)

- Ortho-phenylphenol (bactericide used in tub and toilet bowl cleaners)

Waste Food

Some food waste, whether or not it is run through a waste grinder will not be treated by the system, but will remain in solid form and fall to the bottom of the septic tank. Therefore, you should consider not using a waste grinder system, or disposing of these food items through the Oasis MBR Wastewater Treatment System:

- Animal Bones
- Melon Rinds
- Corn Cobs
- Pips and Seeds
- Eggshells
- Any other non-edible food waste

C. Acceptable Substances:

Substances that are considered to be typical domestic wastewater are human waste, bath and dish water and edible food waste.

The following substances may be used regularly without harming your Oasis MBR Wastewater Treatment System:

- Laundry detergents without bleach
- Dishwashing detergents without bleach
- Toilet Paper
- Household cleaners containing sodium bicarbonate, sodium carbonate and sodium borate.

SECTION 4

SYSTEM MAINTENANCE AND MONITORING

The Oasis MBR Wastewater Treatment System operates automatically and intermittently. The maintenance procedures for the user of the system include keeping the vents and the housing clear of debris. The homeowner should monitor the status of the system, substances introduced into the system, and the frequency of required pump-out as determined by the service provider.

If the instructions in this manual are carefully followed, the Oasis MBR Wastewater Treatment System will provide years of service.

For the homeowner, operational procedures for the Oasis MBR Wastewater Treatment System are minimal. Normal operation of the unit requires intermittent operation and regular discharge of wastewater from the unit. Rubbish must not be allowed to enter the system. All alarm signals are programmed into the PLC (programmable logic controller).

Your Oasis MBR Wastewater Treatment System can be furnished with a service policy, which includes 2-3 inspection/service calls per annum to ensure proper operation of the system. During these service calls, the authorised service person will check for proper operation and perform preventative maintenance including lubrication, cleaning, and inspection of the control PLC. The service provider will also measure the solids level in the septic tank and recommend pump-out when necessary.

PRIMARY CHAMBER

Periodically, waste will need to be removed from the primary chamber using normal pump-out procedures. Only persons experienced in wastewater treatment or service are authorised to remove the chamber cover.

ALARM WARNING

The System is equipped with a red system status light on the control panel and an audio alarm. Should the red light flash and the alarm activate, check the breaker to ensure it has not tripped. If the breaker has tripped, attempt to reset it. If the breaker fails to remain reset, call your Service Technician. The alarm may be shut off by pushing the OFF button. Pushing the OFF button will not reactivate the unit, only silence the alarm.

If your house is without electricity, call the electric company. If the electricity is off more than 48 hours, call your Service Technician as well for treatment system advice.

If your house has electricity but the Plant is not operating, follow the procedures given under ALARM WIRING.

FLOODING

Flood water may cover the septic unit, the PLC cabinet, or both, if the System is installed in a low-lying area.

DANGER: Electrical equipment located in flooded areas presents an electrical hazard. Should the unit become flooded, call your Service Technician. Stay out of flooded area.

EVALUATION OF SYSTEM PERFORMANCE

The Oasis MBR Wastewater Treatment System operates automatically and intermittently. There are no operating procedures for the user of the System to perform. However, as with any home appliance or equipment, simple periodic checks should and can be made to aid in the

prevention of costly repair problems. Generally, the wastewater treatment system unit can be checked by sight and smell.

The Oasis MBR Wastewater Treatment System is an odour-free system. Therefore, there should be no “septic” smell associated with the system, contact your Service Technician.

VISUAL EVALUATION

Wastewater backup is characterised by wastewater flowing back into the house or slow movement of wastewater in the drains. This may indicate a problem with your wastewater treatment system unit. Identify where the backup is occurring within your home’s plumbing system. If no material is blocking the drain, contact your Service Technician.

NO USE FOR AN EXTENDED PERIOD

The Oasis MBR Wastewater Treatment System will function normally even if wastewater does not enter the system for 5 days. The power to the system should be left on during short periods when there is no wastewater flow to the system. If the system will not be used for several months or longer, you should contact your Service Technician so the system can be checked for proper operation and serviced if necessary. A slight odour may be detected for a couple of days while the system returns to normal operation.

SECTION 5

LIMITED WARRANTY

Oasis Clearwater Systems warrants each Oasis MBR Wastewater Treatment System to be free from defects in material and workmanship for a period of two (2) years from the date of sale to the ultimate consumer when properly registered with Oasis Clearwater Systems. Oasis Clearwater System's sole obligation under this warranty is as follows: Oasis Clearwater Systems shall fulfil this warranty by repairing or exchanging any component part, ex Factory, that shows evidence of defects, provided said component part has been paid for, warrantee has notified Oasis Clearwater Systems of the defect complained of and the component is returned through an authorised Distributor, transportation prepaid. There is no informal dispute settlement available under this LIMITED WARRANTY.

No warranty is made as to the field performance of any system. This LIMITED WARRANTY applies only to the parts manufactured by Oasis Clearwater Systems and does not include any portion of the plumbing, drainage or installation of the systems, and does not include any travel or labour. Accessories supplied by Oasis Clearwater Systems, but manufactured by others, are warranted only to the extent of and by the terms and conditions of the original manufacturer's warranty. In no event shall Oasis Clearwater Systems be responsible for delay or damages or any kind of character resulting from, or caused directly or indirectly by, defective components or materials manufactured by others.

Recommendations for special applications will be based on the best available expertise of Oasis Clearwater Systems and published industry information. Such recommendations do not constitute a warranty of satisfactory performance.

This LIMITED WARRANTY extends to the ultimate consumer of the product. As herein, "ultimate consumer" is defined as the purchaser who first has the plant installed, or in the case of a system designed for non-permanent installation, the purchaser who first uses the system. It is the purchaser's or any sub-vendee's obligation to make known to any other consumer, the terms and conditions of this warranty.

This warranty is a LIMITED WARRANTY and no claim of any nature shall be made against Oasis Clearwater Systems unless and until the ultimate consumer, or his legal representative, notifies Oasis Clearwater Systems in writing of the defect complained of and delivers the product and/or defective part(s), freight prepaid, to Oasis Clearwater Systems or an authorised service agent.

Oasis Clearwater Systems reserves the right to revise, change or modify the construction and design of the Oasis MBR Treatment System, or any component part or parts thereof, without incurring any obligation to make such changes or modifications in equipment previously sold. Oasis Clearwater Systems also reserves the right, in making replacements of component parts under this warranty, to furnish a component part which, in its judgement is equivalent to the part replaced.

SECTION 6

MANAGEMENT PLAN

A. Contact Details:

Manufactured by:	Oasis Clearwater Environmental	Date:	
System Type:	Oasis MBR		
Designed By:		Installed By:	
Contact details:		Contact details:	
		24Hr Contact No.	

B. Design Discharge Volume:

Tank	Volume (Lt)	Tank	Volume (Lt)
Anoxic	1,300		
MBR	5,000		
		Pump Out	1,300
Total Operating Volume	7600	Spare Capacity	1800
Total Holding Volume	9400	Design Capacity	10 People - 1800

C. Process Flow Diagram:

Attach Drawing 1.

D. Process Description:

Process Type	Oasis MBR	Other Devices:	
House Design Volumes		Flow Meter	
Drip Loading Rate		Splitter Device	
Drip Area		UV Protection	

This plant is constructed in two configurations one multi-chambered concrete tank or two multi-chambered plastic tanks and has a nominal holding capacity of 10,500 litres.

SECTION 7

TROUBLE SHOOTING

PROCESS FAILURE

Process failure from oxygen starvation of the biomass and MBR filtration process:

If the biomass is starved of oxygen, the typical odours associated with anaerobic bacterial treatment will be noticed. This is caused by insufficient air flow into the biological zone. A blockage or blower failure is the most probable cause.

- a) The blower is equipped with an inlet screen. If this screen becomes blocked with debris, it could cause oxygen starvation of the biomass. The blower inlet screen should be checked every 6 months and replaced as needed.

TROUBLESHOOTING GUIDE

PROBLEM	POSSIBLE CAUSES	SOLUTIONS
The indicator light on the control panel is flashing and the audible alarm is on. All fault codes appear on the PLC screen		Read fault message and respond to message on screen.
Fault message reads high level in MBR chamber	Permeate valve or level sensing failure	Check valve and level for operation check inlet screen for blockage.
	MBR blocked	Perform Hypo clean.
	The system is flooded.	Determine cause of flooding and correct.
	Permeate valve not operating.	Check for operation and correct flow patterns.
	Circuit breaker tripped	Investigate overheating (i.e. internal thermal overload protection), short-circuiting, or other electrical failure (i.e. bearing failure) and correct.
Fault message reads high level in irrigation chamber	Pump or float failure	Check pump and float for operation check inlet screen for blockage
	Filter blocked or frozen	Clear and clean
PROBLEMS	POSSIBLE CAUSES	SOLUTIONS

	Circuit breaker tripped	Investigate overheating (i.e. internal thermal overload protection), short-circuiting, or other electrical failure (i.e. bearing failure) and correct.
	Field disposal system turned off or blocked	Check the piping and lateral field piping visually or with drain cleaning equipment for an obstruction and correct.
Wastewater is backing up into the home sewer piping	There is an obstruction in the home sewer piping.	Check the piping lead to the system visually or with drain cleaning equipment for an obstruction and correct.
	There is an obstruction in the discharge line from the system.	Check the effluent piping and lateral field piping visually or with drain cleaning equipment for an obstruction and correct.
	The lateral field pump has failed	Check the operation of the lateral field pump per the pump manufacturer's specifications.
	The flow rate to the system is too high.	Check the maximum flow rate to the system to see that it is within normal limits.
	The tank requires cleaning and/or a pump out is required.	Check the sludge depth in both chambers of the tank to see if it is below required levels. If the depth is too great, have the tank pumped out and, if necessary, cleaned.
There is an unpleasant odour emanating from the unit.	The blower and air vents are not operating correctly.	Check the blower, vents and piping for proper operation.
	The system is overloaded.	Check the maximum flow rate to the unit to see that it is within normal limits.
		Check the quality and contents of the flow into the unit for any abnormal or prohibited substances.

PROBLEM	POSSIBLE CAUSE	SOLUTIONS
	The power cable to the blower has been damaged or is not connected properly.	Have a certified electrician check the wiring to the pump.
	The original cause for alarm has been corrected, but the flashing circuit for the indicator light has not been reset by technician	Reset < on PLC.
The audible alarm is on.	An alarm condition has occurred. See troubleshooting items under flashing alarm indicator.	Push mute button to silence alarm.
Pump or pumps are making a loud whining or grinding noise.	A foreign object has entered pump housing.	Remove pump for service and check condition of inlet.
The PLC is flooded.	Water has entered the PLC cabinet.	The PLC should be located in an area where water does not accumulate.

SECTION 8

SERVICE PROCEDURE

OASIS MBR

COMMISSIONING AND SERVICING PROCEDURE

Prior to arriving on site to service or commission a newly installed System, check that the electrician has completed the wiring in accordance with wiring diagram supplied, and power is connected to the house.

1. Confirm with owner that sufficient water is available in the Tank to allow proper operation.
2. Remove all lids to allow access to all chambers.
3. Check PLC and all electrical connections are OK
4. Check permeate valve for operation.
5. All valves and flows are factory pre-set for these details please contact Oasis
6. Test the high water alarm floats, one in MBR chamber and one in irrigation chamber by manually lifting the float, and check that the audio-visual alarm installed in the house is working (if fitted).

Initial start up:

7. Partial fill influent chamber with water
8. Fill MBR chamber with water to TWL.
9. Turn power on to plant.
10. Perform clean water flux test.
11. Lower MBR chamber to BWL
12. IMPORTANT-Seed plant with activated sludge
13. IMPORTANT-Insure MLSS (Mixed Liquor Suspended Solids) is between 3000/5000mg/l.
14. PLC set to auto and check operation.
15. Double check the audio-visual alarm and make sure the Mute button is in the ON position.

Irrigation field needs to be inspected for even effluent distribution over the disposal area.

Ensure correct NAME & ADDRESS is on Service Report.

1. Identify yourself to home owner.
2. Remove shoes, enter house and check control panel lights and switches.
3. Visually inspect the treatment plant including landscaping lines and drippers.
4. Remove all turret lids.
5. Turn field isolator to "OFF" position when servicing inside PLC cabinet.
6. Check primary sludge depth if over 2/3 tank depth advise customer to have pumped out.
7. Remove and clean filter as necessary (Arkal and Zabel).
8. Check operation of all level sensing devices and alarm levels.
9. Check permeate valve for operation.
10. Check Dissolved Oxygen (DO) with DO probe 2-7 mg/L.
11. Collect a sample from inside the pump well and carry out tests for:
 - a) Clarity - average 70 – 100% reading
 - b) Residual Chlorine - average 2 mg/l
 - c) pH - 7.0 – 8.0 reading
12. Replace all covers accurately and make sure the field isolator is switched ON **(IMPORTANT)**.
13. Fill in Service Report Sheet accurately
Leave ONE copy with home owner
One Copy to be sent to relevant Council
One copy to OASIS CLEARWATER
Retain one copy

SECTION 9

EXCAVATION DETAILS

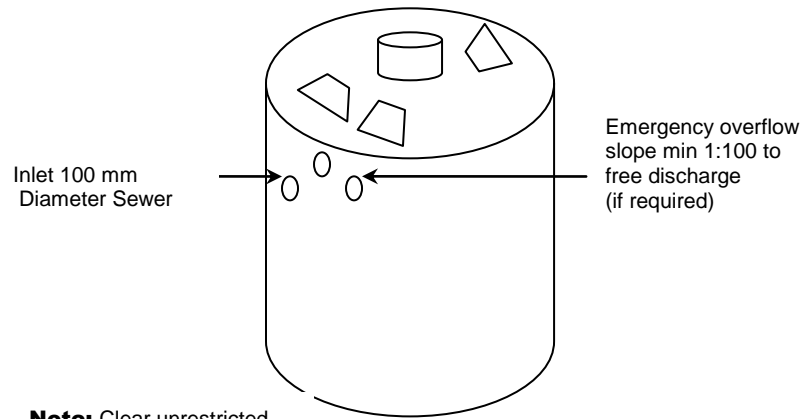

Note: Clear unrestricted stable access to one side of excavation for tank

Hole 2800 mm square or round – approx. 2300 mm deep

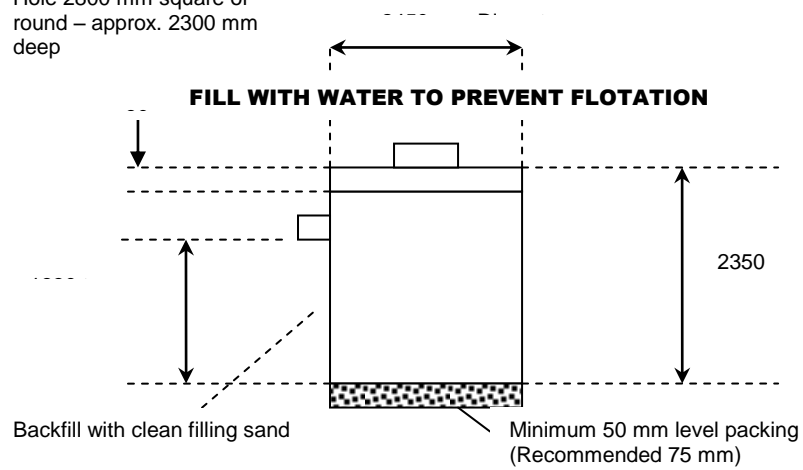

SECTION 10

ELECTRICAL REQUIREMENTS AND WIRING DIAGRAM

Electrical Specifications

The electrical equipment within the Oasis MBR Unit consists of one 600 and one 250 watt pump, two 120 watt Blowers and an electrical distribution PLC (programmable logic controller), all installed on the Oasis MBR Unit.

Electrical Requirements to be provided by Owner's Electrician:

A 230Volt AC 2.5mm TPS dedicated supply must be provided from the mains-board supply to the Oasis MBR Unit.

Also a two core 1.5mm TPS cable is to be connected between the terminals in the PLC and the alarm unit (as supplied). Alarm unit should be mounted in a convenient inside location e.g. in a garage or shed.

All alarm fault messages will appear on the PLC screen. The alarm unit operates on 24V DC.

Power supply and cable should be sized to avoid any voltage drop. A higher than normal liquid level will sound the alarm, and activate the red lamp. This can be muted until normal operation is restored, by placing the alarm in the mute position.

Two high level alarms are programmed in to the PLC; a malfunction of either the MBR or the irrigation pump will trigger an alarm. A malfunction in any circuit breakers should not be reset until the reason for the trip out is established and any malfunction is rectified.

All alarms and motor connections are hard wired into the PLC. The only wiring required is the supply cable, clearly labelled in the PLC. NO RCD unit is required.

The 3 pin socket in the PLC box is 230V AC and is for servicing or to run a UV sterilization unit.

All sequential timing and pump run times are pre programmed into the PLC and are code locked to avoid tampering. Any programme changes should only be done in conjunction with Oasis Clearwater Environmental Systems.